

Wingline 78

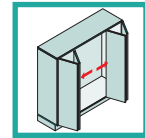

Folding door fitting for: 1 x folding door with 2 x panels



Function / Assembly

2-panel door set

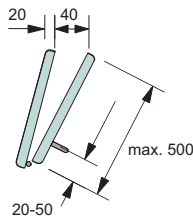

Recommended door panel contours for reducing risk of crushing

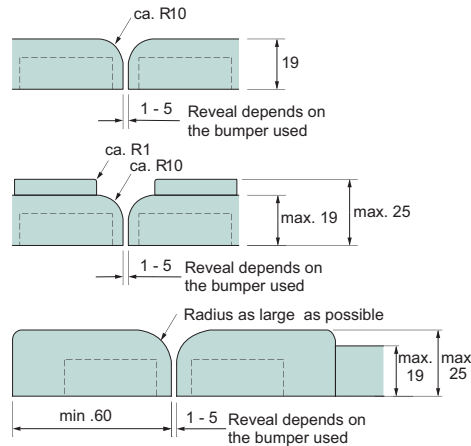

2-panel folding door

Panel width max. 1000 mm
 Door weight/panel max. 10 kg
 Door panel height max. 2200 mm

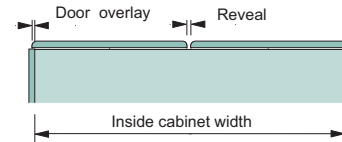
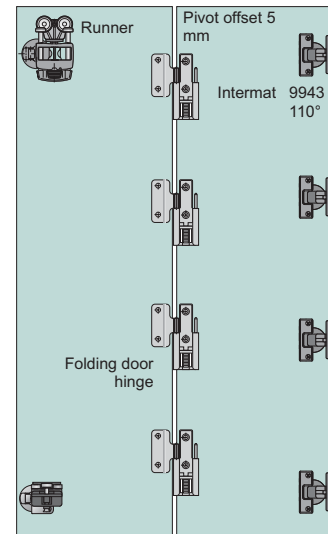

Calculation of door width/door panels

$$\text{Door width} = \text{inside cabinet width} + (2 \times \text{overlay}^*)$$

$$\text{Door panel width} = \text{inside cabinet width} - (1 \times \text{reveal}) + (2 \times \text{overlay}^*) \div 2$$

* Overlay: max. 15 mm, C value 5 mm

Drilling pattern

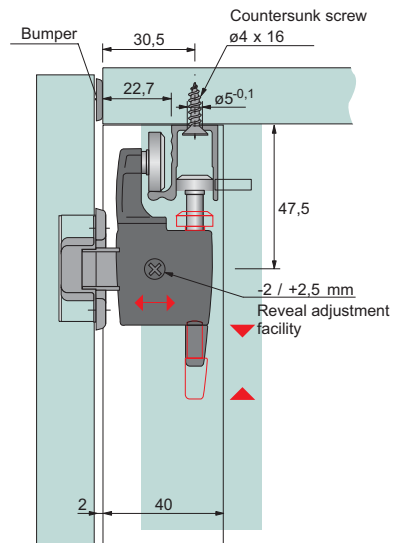
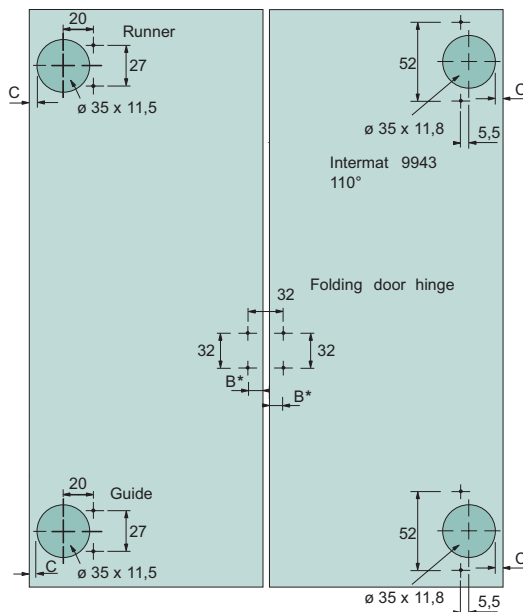

* B Hole spacing mm	13,5	14	14,5	15	15,5
Reveal mm	5	4	3	2	1